

"MD2SR" Series:
Heavy Duty Single Throw Safety Switch with Interlocked
Appleton Powertite Compatible Receptacle.

Class I Div. 2 Group B, C, D, T3C
Class II Div. 1 Group F, G
NEMA Type 3, 3R, 4, 4X, 12 (Screw Cover Option)

Electrical Rating:

Maximum Voltage: 600 VAC at 60 Hz, 250 VDC 30, 60 or
100 Amperes, depending on current rating of product (See
product nameplate for details).

Instructions for Installation, Operation and Maintenance of
"MD2SR" Interlocked Receptacle with Switch: 30, 60 & 100
Ampere.

Compliances:

- UL Listed, File No. E10784
- UL1682 Standard for Plugs, Receptacles, and Cable
Connectors of the Pin and Sleeve Type
- UL1010 - Plug Combinations for use in Hazardous Location
- UL98 - Enclosed and Dead-Front Switches
- UL50 - Enclosures for Electrical Equipment
- UL894 - Switches for use in Hazardous Locations
- NEC wire bending space, Table 373-6(B).

Read instructions carefully and with full understanding for safe installation and operation.

TABLE A - HORSEPOWER RATING:

DC VOLTS	AC VOLTS	AMPERES	CATALOG NUMBERS	SWITCH TYPE	H.P. RATING	
					AC	
					STANDARD	MAX
250	600	30	MD2SR3023F MD2SR3034F	FUSED	7.5	20
250	600	30	MD2SR3023U MD2SR3034U	NON-FUSED	--	30
250	600	60	MD2SR6023F MD2SR6034F	FUSED	15	50
250	600	60	MD2SR6023U MD2SR6034U	NON-FUSED	--	50
250	600	100	MD2SR1023F MD2SR1034F	FUSED	30	50
250	600	100	MD2SR1023U MD2SR1034U	NON-FUSED	---	50

FIGURE A

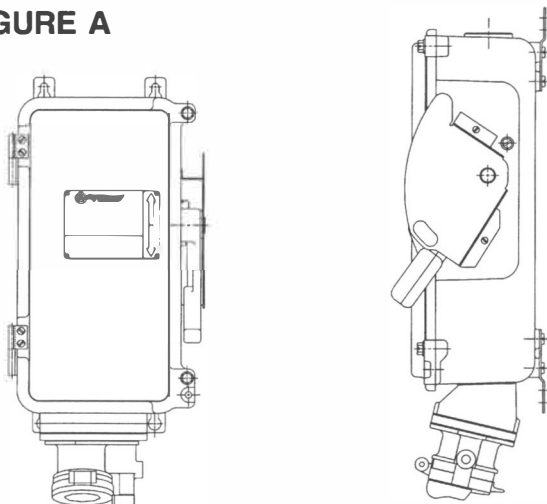

STANDARD FEATURES:

- Epoxy coated finish on receptacle and disconnect switch housing.
- Current carrying parts in housing are all plated copper, receptacle contacts are brass.
- Lugs - front removable, standard mechanical lugs on incoming line. Lay-in ground lug.
- Screw cover assembly provided for use on receptacle housing, instead of flip cover assembly to meet NEMA Type 4 and 4X environmental conditions.

Except as expressly provided by Appleton Electric, LLC (Appleton) in writing, Appleton products are intended for ultimate purchase by industrial users and for operation by persons trained and experienced in the use and maintenance of this equipment and not for consumers or consumer use. Appleton warranties do not extend to, and no reseller is authorized to extend Appleton's warranties to, any consumer.

APPLICATION:

- Designed to supply three(3) phase, grounded electrical power to portable or fixed electrical equipment such as welders, infrared ovens, batch feeders, conveyors and truck and marine docks.
- Designed to provide an interlocked receptacle for use in hazardous locations, as defined in the National Electrical Code (NEC). In addition, the receptacle is designed such that a mating plug can only be engaged and disengaged when the switch handle is in the "OFF" position.
- Ideal for use on shipping docks, ports, and other "ship to shore" applications.
- Suitable for use in locations that require a degree of protection from the elements indoors and outdoors (NEMA Type 3R & 12) for the receptacle flip cover and (NEMA 3, 3R, 4, 4X and 12) for the receptacle screw cover.
- Enclosure cover is gasketed to seal cover against the enclosure housing.
- The receptacle face enables the engagement of mating plugs for a weatherproof union.
- MD2SR Series Interlocked Receptacle may be pole mounted or installed on flat vertical surfaces.

TABLE B: "ACP" PLUGS FOR "MD2SR" RECEPTACLES

RECEPTACLE CAT. NO.	SWITCH ASSEMBLY CAT. NO.	CURRENT RATING	APPLETON MATING PLUGS	CROUSE-HINDS MATING PLUGS		
WRDK3023	MD2SR3023F	30	ACP3023BC	APJ3385	NPJ3383	NPJ3384
WRDK3023	MD2SR3023U	30	ACP3023BC	APJ3385	NPJ3383	NPJ3384
WRDK3034	MD2SR3034F	30	ACP3034BC	APJ3485	NPJ3483	NPJ3484
WRDK3034	MD2SR3034U	30	ACP3034BC	APJ3485	NPJ3483	NPJ3484
WRDK6023	MD2SR6023F	60	ACP6023BC	APJ6385	NPJ6384	NPJ6385
WRDK6023	MD2SR6023U	60	ACP6023BC	APJ6385	NPJ6384	NPJ6385
WRDK6034	MD2SR6034F	60	ACP6034BC	APJ6485	NPJ6484	NPJ6485
WRDK6034	MD2SR6034U	60	ACP6034BC	APJ6485	NPJ6484	NPJ6485
WRDK1023	MD2SR1023F	100	ACP1023CD	APJ10387	NPJ10386	NPJ10387
WRDK1023	MD2SR1023U	100	ACP1023CD	APJ10387	NPJ10386	NPJ10387
WRDK1034	MD2SR1034F	100	ACP1034CD	APJ10487	NPJ10486	NPJ10487
WRDK1034	MD2SR1034U	100	ACP1034CD	APJ10487	NPJ10486	NPJ10487

TABLE C: TIGHTENING TORQUE - DISCONNECT SWITCH LUG SCREWS

WIRE SIZE (AWG)	TORQUE (LB-IN)
#8	40
#4 - #6	45
#4/0 - #3	50

TIGHTENING TORQUE FUSEHOLDER LUG SCREWS

WIRE SIZE (AWG)	TORQUE (LB-IN)
#10 - #14	35
#8	40
#4 - #6	45
#2/0 - #3	50

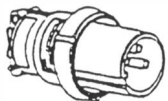

ACP PLUG

WARNING

Electrical power must be turned "OFF" before and during installation and maintenance.
Failure to do so may result in serious / fatal injuries due to electrocution.

WARNING

Do not modify these devices in any way. Replace any missing or broken parts with the proper replacement parts from Appleton Electric, LLC. Modification of these devices or substitution of parts with non-standard parts may result in serious / fatal personal injury from electrocution.

WARNING

The "MD2SR" receptacles are designed and tested for use with copper conductors only.
DO NOT use aluminum wiring, as dangerous overheating and fire may result.

WARNING

If any parts of the "MD2SR" unit appear to be missing, broken or show signs of damage:
DISCONTINUE USE IMMEDIATELY!
 This condition could cause serious / fatal personal injury due to electrocution and / or equipment damage. Repair with the proper replacement part(s) before continuing service.

WARNING

Not suitable for use as service equipment.

FIGURE B: CONTACT PHASE IDENTIFICATION MARKINGS

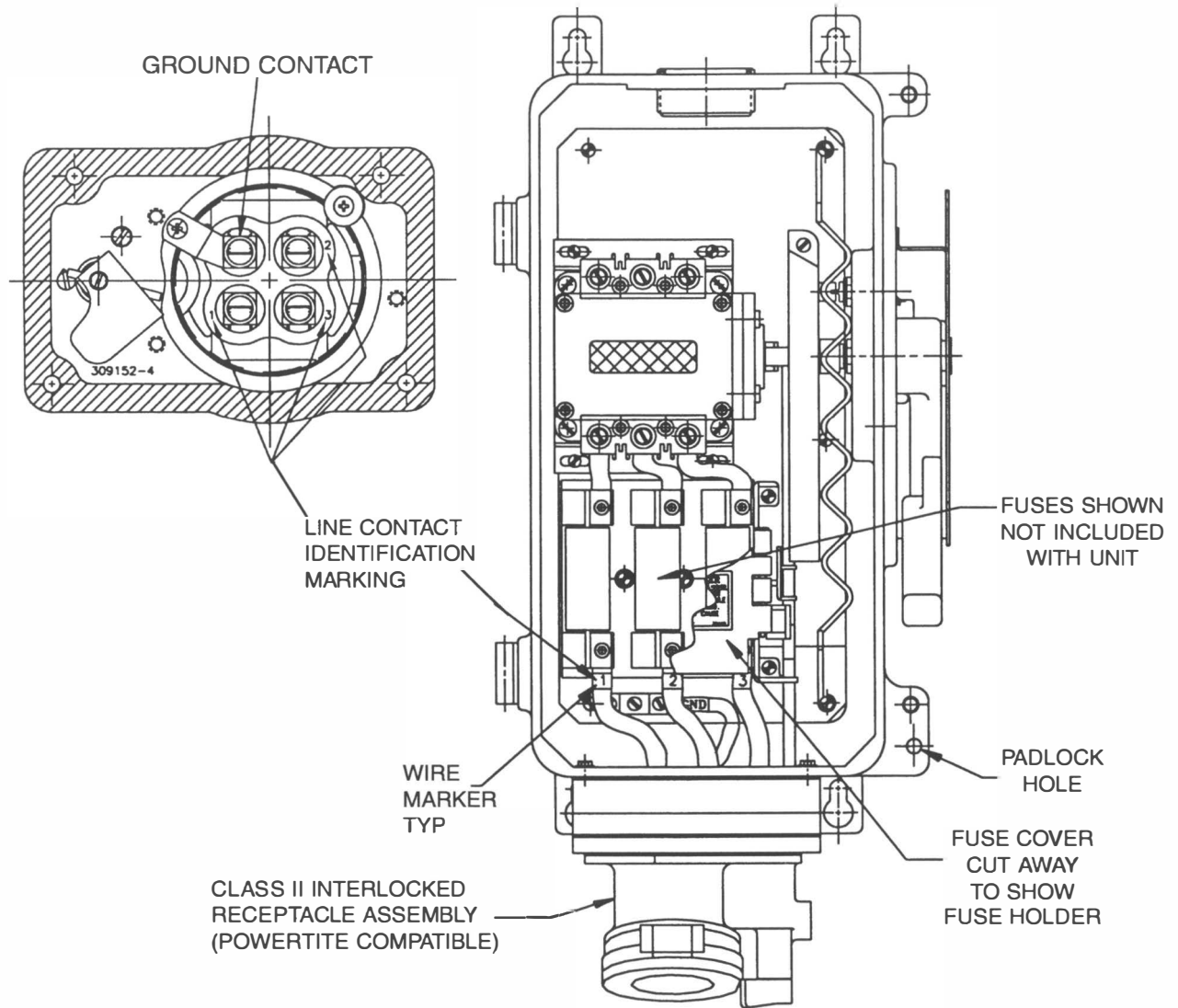

(ASSEMBLY VIEW WITH COVER REMOVED) - UNIT SHOWN IS CAT. NO. MD2SR1034F

FIGURE C: MD2SR INTERLOCKED RECEPTACLE

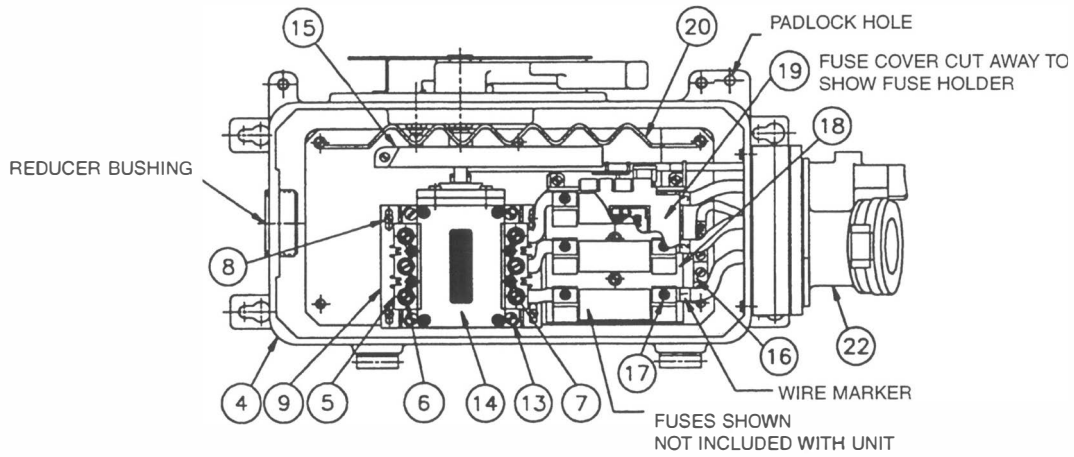

(ASSEMBLY VIEW COVER REMOVED) - UNIT SHOW IS CAT. NO. MD2SR1034F

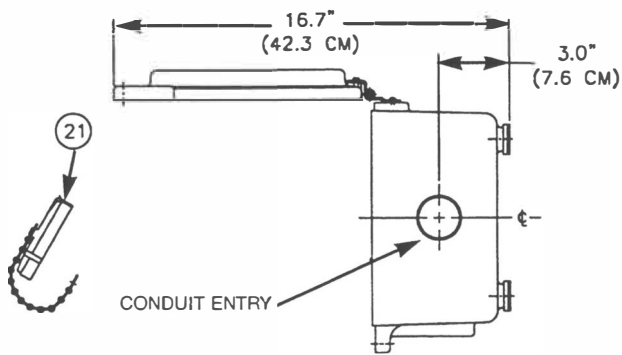

CATALOG NUMBER	DIMENSION "A"
MD2SR3023F	19.3" (48.9 CM)
MD2SR3023U	
MD2SR3034F	
MD2SR3034U	
MD2SR6023F	
MD2SR6023U	
MD2SR6034F	
MD2SR6034U	
MD2SR1023U	
MD2SR1034U	
MD2SR1023F	22.9" (58.1 CM)
MD2SR1034F	

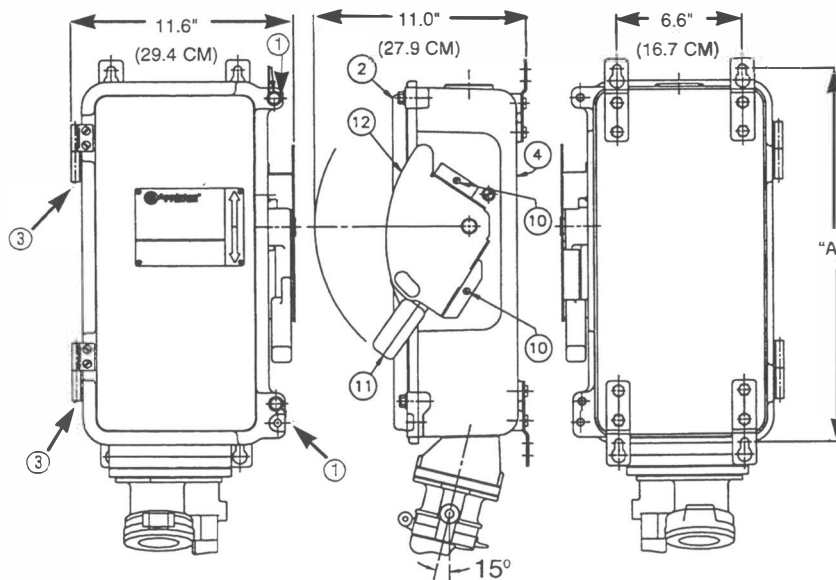

INSTALLATION INSTRUCTIONS FOR "MD2SR" SERIES RECEPTACLES 30, 60 & 100 AMP

INSTALLATION

1. PREPARE MOUNTING POSITION:

Owners are responsible for damages or injuries if these rules are not followed.

WARNING

- Before starting with the installation, make sure the enclosed switch assembly is suitable for the intended location according to the National Electrical Code or Canadian Electrical Code.
- If the enclosed switch assembly is not suitable, serious damage and injuries may result.

- A. The Interlocked Receptacle assembly must be mounted on (4) 3/8" max. diameter steel, hex-head bolts per ANSI and B18.2.1-1981, securely fastened to wall, column, strut, or other vertical structure, in one plane, capable of supporting the assembly, its associated conduit and wiring. Mounting bolts are not provided with the assembly.
- B. Referring to "FIGURE B" for dimensions of the "MD2SR" Interlocked Receptacle, prepare the structure for the mounting bolts by drilling, tapping, securing nuts or another method of providing threaded anchors for the bolts.
- C. Install the bolts leaving 3/8" to 1/2" under the heads.
 - The bolts must be engaged at least five (5) full threads.

2. MOUNTING THE RECEPTACLE ASSEMBLY:

- A. Place the receptacle assembly on the previously prepared mounting bolts, with the Operating Handle ⑪ on the right side if facing the unit (SEE "FIGURE C"). Make sure that the shank of the bolts is in the small part of the key-hole slots in all four cases. Tighten the bolts to 18 to 20 lb. - ft. torque.

3. OPENING HOUSING COVER:

- A. Referring to "FIGURE C", loosen the housing Cover Bolts ①, but do not attempt to remove them completely from the Cover ② because they are designed to be captive.
- B. The Cover ② is now free to swing open on its factory installed Hinges ③.
- C. Although it is not necessary, the Cover ② can be removed from the Housing ④ by carefully lifting the Cover enough to clear the hinge pins; approximately 1 inch.
- D. It is recommended that if removed, the Cover be placed outer surface down on clean wood. Then protect with a tarp or other covering to maintain cleanliness and damage-free conditions.

4. CONDUIT INSTALLATION:

- A. Note that a 1-1/2" NPT conduit entry is provided at the top of the Housing ④. 1-1/2" to 1-1/4" and 1-1/2" to 1" Reducer Bushings are provided and can be used if desired.
- B. Make sure that conduit entries are clean and free of debris before installing conduit or bushings.
- C. Grease must be used on conduit and reducer bushing threads to completely seal out water.
 - Appleton Electric, LLC thread lubricant, part no. TLC-3, is recommended to be applied on threads in three generous lines running parallel to the thread axis and spaced equidistant around the thread.
- D. Conduit must be turned in until snug and then 1/2 turn further with a wrench.
 - Do not over-tighten as damage to the threads in the Housing or Reducer Bushing may occur.

5. WIRING:

WARNING

- The "MD2SR" Receptacles and Fuse Holders are designed and tested for use with copper conductors only.
- DO NOT USE ALUMINUM WIRING as dangerous overheating and fire may result.

WARNING

Electrical power must be turned "OFF" before and during installation and maintenance.

Failure to do so may result in serious / fatal injuries due to electrocution.

5. WIRING (CONTINUED):

TABLE D: TERMINAL WIRE RANGE AND STRIPPING GUIDE

AMPERE RATING	STRIP LENGTH (INCHES)	TERMINAL WIRE RANGE (AWG)
	CONDUCTOR "A"	BUILDING WIRE
30	.63	#8 - #6(CU)
60	.63	#6 - #2(CU)
100	.63	#4 - #4/0(CU)

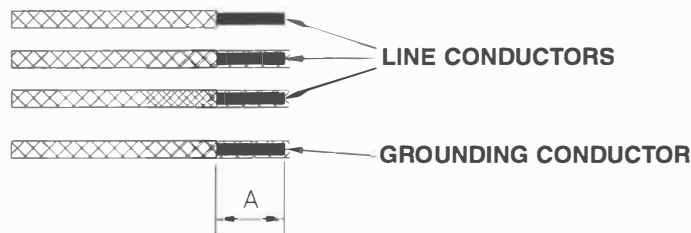

- A. Referring to "FIGURE C" feed power supply wiring into Housing ④ through conduit entry.
- B. Strip the individual conductors per "TABLE D".
- C. Connect wires to the Line Side Lugs ⑤ of the Disconnect Switch by loosening, but not removing Lug Screws ⑥. Insert conductors including all strands into lugs according to your established wiring scheme. Tighten Lug Screws ⑥ to the appropriate value shown in "TABLE C". Please note the wire markers on the wires connected between the Receptacle ⑳ and either the Disconnect Switch Load Side Lugs ⑦ or Fuse Holder Lugs ⑰. These wire markers correspond to the contact identification markings found on the back of the receptacle contact block. Refer to "FIGURE B".
- D. Fused Switches are equipped with an installed Fuse Holder ⑱ and interlocked Fuse Holder Cover ⑲. The Cover can only be opened when the Switch is in the "OFF" position. Attempts to open the Cover while the Switch is "ON" may damage the Cover. The purposes of the Cover are: personnel safety from shock hazard of energized electrical parts and to prevent removal of a fuse while Switch is "ON" which could cause an arc in a potentially explosive atmosphere.
- E. For fused units, install appropriate amperage fuses into Fuse Holder ⑱. Use only sand filled, non renewable Class J Fuses.
- F. Wire Guide ㉑ allows wiring to be run from the top or bottom of the Enclosure to the opposite end of the Enclosure without interference with the Switching Mechanism. Wiring should be held to Wire Guide by the use of cable ties.

6. ELECTRICAL TESTING:

All wiring must be checked and tested to ensure that all circuits are according to plan and that there are no unwanted opens, shorts or grounds.

Do not apply power until the following steps are completed:

- A. Test to verify correct phasing and ground connections.
- B. Test insulation resistance by meggering high voltage or hi-pot test, to be sure the system does not have any short circuits or unwanted grounds.

7. CLEAN COVER AND HOUSING:

Before closing the Cover ②, it is strongly recommended that all dirt, debris and other foreign materials be removed from the interior.

- This action should be taken to help eliminate the possibility of unwanted shorts or grounds.
- Make sure the cover gasket surface is clean and free of any tears or damage.
- Clean the mating surface of the Housing ④ in the same manner as the Cover ②.

8. CLOSE COVER:

- A. If the Cover ② was removed, carefully rehang the Cover ② on the Hinges ③ while the Cover is positioned approximately 90 degrees from the Housing.
- B. Close the Cover ②. Start the two Housing Cover Bolts ① by hand to prevent cross-threading.
 - Tighten the Cover Bolts to 25-30 lb.- ft. torque.
 - Do not over-tighten since there is a possibility of stripping threads in the Housing.

9. POWER:

With all electrical tests successfully made, the Cover Bolts tightened and the Receptacle turned "OFF", power may be applied to the "MD2SR" unit.

10. OPERATION:

- A. With an appropriate mating plug engaged, the Receptacle can now be turned to the "ON" position by lifting the Operating Handle ⑪ to the upper-most position.
- Safety feature - The Receptacle is interlocked to the Operating Handle Mechanism so that a mating plug may not be inserted or removed when the switch is in the "ON" position.
- B. A hole is provided in the Housing Lock-Out ⑫ and Operating Handle ⑪ for the use of a padlock (See "FIGURE B") to prevent unauthorized movement of the Operating Handle ⑪ from the "OFF" position.

11. FUSE REPLACEMENT:

- A. Turn Receptacle to "OFF" position by moving Operating Handle ⑪ to lower most position. Place padlock in Housing Lock-Out.
- B. Loosen (2) Cover Bolts ① and open Enclosure Cover.
- C. Open Fuse Holder Cover ⑲ by grasping tab on left side.
- D. Remove and replace fuses as needed. Use only Type J sand filled, non-renewable fuses, per 1996 National Electrical Code Article 501-6 (b) (3).
- E. Close Fuse Holder Cover ⑲.
- F. Close Enclosure Cover ② and tighten Bolts to 25-30 lb.- ft. torque.
- G. Remove padlock.

12. MAINTENANCE:

After all Maintenance Procedures, test for correct electrical connections and mechanical function before applying power.

- A. INSPECTION: Receptacle must be inspected regularly. Schedule of inspections is determined by frequency of use and environmental conditions.
- It is recommended that inspections be carried out at least once a year.
- B. DISCONNECT SWITCH REPLACEMENT: Disconnect Switches occasionally fail with use and need to be replaced. Replacing the Appleton Electric, LLC. LAB10® Switch ⑭ with another LAB10 Switch will not affect the UL listing of the MD2SR Interlocked Receptacle.

To Remove LAB10 Switch from Housing

- Referring to "FIGURE C", loosen line side Lug Screws ⑥ of the Disconnect Switch and remove line side wires from the Switch.
- On non-fused units, loosen load side Lug Screws ⑦ of the Disconnect Switch and remove wires from the Receptacle ⑳. On fused units, loosen load side Lug Screws ⑦ and carefully disengage the Fuse Holder leads.
- Please take note of the orientation of these wires for proper reassembly.
- Remove the Switch's Mounting Screws ⑬ and carefully disengage Switch from Switching Mechanism ⑮. by moving sideways away from Mechanism.
- Remove the Switch ⑭ from Housing ④.

To Replace LAB10 Switch into Housing

- Carefully slide Switch into Switching Mechanism ⑮, ensure that there is a minimum of 1/4" engagement between the LAB10 Switch and the Switching Mechanism.
- On fused units, carefully insert Fuse Holder leads into load side terminals. On non-fused units, carefully insert receptacle wires into the load side terminals.

Always be careful to maintain proper orientation of line side and load side wires.

- Insert the Switch's Mounting Screws ⑬ and torque to a value of 15-20 lb. - in.
- Insert the line side wires into the line side terminals.
- Torque line side ⑥ Lug Screws to the appropriate values shown in "TABLE C". On fused units, torque load side Lug Screws ⑦ to a value of 50 lb. - in. On non-fused units, torque load side Lug Screws ⑦ to a value of 40 lb.-in. for 30 AMP units, 45 lb.-in. for 60 AMP units, and 50 lb.-in. for 100 AMP units.

C. OPERATING HANDLE REPLACEMENT:

To Remove Handle

- Referring to "FIGURE B", remove the two Handle Lock-Out Screws ⑩ and remove Housing Lock- Out ⑫.
- Remove Operating Handle ⑪ from Disconnect Switch mechanism assembly ⑮.

To Replace Handle

- Place new Operating Handle ⑪ onto Disconnect Switch mechanism assembly ⑮.
- Place Housing Lock-Out ⑫ onto Operating Handle and replace screws.
- Tighten screws to a torque of 20-25 lb. - in.

D. SWITCHING MECHANISM REPLACEMENT:

To Remove Switching Mechanism

- Remove LAB10 Switch by following the instructions in 12 B.
- Remove four Mounting Screws ⑧ for Switch Mounting Bracket ⑨, remove Switch Mounting Bracket.
- For fused units, remove Rod Assembly.
- Remove Switching Mechanism Mounting Screws, remove Switching Mechanism ⑩.

To Replace Switching Mechanism

- Slide new Switching Mechanism into place, insert Mounting Screws.
- Torque Mounting Screws to 15-20 lb. - in.
- For fused units, slide Rod Assembly into place.
- Replace Switch Mounting Bracket ⑨, torque Mounting Screws ⑧ to 15-20 lb. - in.
- Follow instructions for replacement of LAB10 Switch in 12. B.

E. FUSE COVER ASSEMBLY (FUSED UNITS) REPLACEMENT:

To Remove Fuse Cover Assembly

- Follow instructions for removal of LAB10 Switch in 12. B.
- Remove four Mounting Screws ⑧ for Switch Mounting Bracket ⑨, remove Switch Mounting Bracket.
- Remove Rod Assembly.
- Remove Fuse Cover Assembly Mounting Screws, remove Fuse Cover Assembly.

To Replace Fuse Cover Assembly

- Position new Fuse Cover Assembly in place.
- Replace Fuse Cover Assembly Mounting Screws and torque to 15-20 lb. - in.
- Slide Rod Assembly through opening in Fuse Cover Assembly.
- Engage Rod Assembly onto Switching Mechanism.
- Replace Switch Mounting Bracket ⑨, torque Mounting Screws ⑧ to 15-20 lb. - in.
- Follow instructions for replacement of LAB10 Switch in 12. B.

F. RECEPTACLE ASSEMBLY SCREW COVER INSTALLATION:

- Referring to "FIGURE C", loosen the three flip cover assembly mounting screws which fasten the flip cover assembly to the Receptacle Housing ⑳. Remove the flip cover assembly by carefully lifting it off of the Receptacle Housing. Retain for future use, if desired.
- Remove one of the five receptacle housing mounting screws. Thread receptacle assembly Screw Cover ㉑ onto the Receptacle Housing ㉒ until screw cover gasket is firmly seated against the receptacle housing face. Replace the receptacle housing screw, secure the free end of the Screw Cover chain to housing by passing the screw through the lug at the end of the chain.

G. RECEPTACLE ASSEMBLY:

Electrical contacts eventually wear out, due to the amount of use the unit they are installed in experiences or due to environmental conditions. The Receptacle Assembly can, therefore, be replaced. The Receptacle Assemblies can be replaced with the same type and brand as factory installed. Doing so will not affect the UL listing. Refer to "TABLE E" for replacement parts.

To Replace Receptacle Assembly

- Referring to "FIGURE C", loosen the Load Side Lug Screws ㉓ of the Disconnect Switch ㉔ or Fuse Holder ㉕, if applicable, and remove wires.
- Disconnect and remove wire from Ground Lug ㉖.
- Remove the four (4) Receptacle Assembly Mounting Screws that fasten the assembly to the Housing ㉗. Support the assembly so that it does not fall from unit. Remove Receptacle Assembly.
- Replace with the new Receptacle Assembly. Replacing the unit can be accomplished by reversing the steps needed to remove it. Tighten the four (4) Receptacle Assembly Mounting Screws to 19-25 lb.-in. to secure unit to housing.
- Place the appropriate wires into the correct lug locations and tighten lug screws to the appropriate value shown in "TABLE C".
- Test the unit for proper function by performing the following tasks:
With power not being applied to the assembly, close the cover ㉘, insert an appropriate mating plug, and throw the switch to the "ON" position to make sure that there is no interference between the new Receptacle Assembly and Switch. If unit functions properly, it can be returned to service. If unit does not function properly, check the mounting of the Receptacle Assembly to the housing. Do not allow unit to be used until problem is corrected.

H. GROUND LUG REPLACEMENT:

- Referring to “FIGURE B”, loosen the Ground Lug Screw and remove ground wire from the Lug.
- Remove Ground Lug Mounting Screw from the Mounting Plate.
- Replace Ground Lug ⑬ with the appropriate one shown in “TABLE E”.
- Torque Ground Lug Mounting Screw to 16-20 lb.- in. to fasten Ground Lug to Mounting Plate.
- Reconnect ground wire to Lug and tighten Lug Screw to 30-40 lb.- in. torque.

TABLE E

MD2SR INTERLOCKED RECEPTACLE REPLACEMENT PARTS					
REFERENCE NUMBER	AMPACITY	DESCRIPTION	PART NUMBER	QUANTITY PER ASSEMBLY	ASSEMBLIES USED IN
1	30, 60, 100	DISCONNECT SWITCH	LAB10	1	MD2SR3034F MD2SR6034F MD2SR1034F MD2SR1034U
2	30, 60, 100	OPERATING HANDLE	59308352000	1	MD2SR3034F MD2SR6034F MD2SR1034F MD2SR1034U
3	30, 60, 100	SWITCHING MECHANISM	59312769000	1	MD2SR3034F MD2SR6034F MD2SR1034F MD2SR1034U
4	30, 60	FUSE COVER ASSEMBLY	59351030000	1	MD2SR3034F MD2SR6034F
5	100	FUSE COVER ASSEMBLY	59351031000	1	MD2SR1034F
6	30	CLASS II RECEPTACLE ASSEMBLY 30 AMP; 2 WIRE, 3 POLE	59312775000	1	MD2SR3023F MD2SR3023U
7	30	CLASS II RECEPTACLE ASSEMBLY 30 AMP; 3 WIRE, 4 POLE	59312766000	1	MD2SR3034F MD2SR3034U
8	60	CLASS II RECEPTACLE ASSEMBLY 60 AMP; 2 WIRE, 3 POLE	59312776000	1	MD2SR6023F MD2SR6023U
9	60	CLASS II RECEPTACLE ASSEMBLY 60 AMP; 3 WIRE, 4 POLE	59312767000	1	MD2SR6034F MD2SR6034U
10	100	CLASS II RECEPTACLE ASSEMBLY 100 AMP; 2 WIRE, 3 POLE	59312777000	1	MD2SR1023F MD2SR1023U
11	100	CLASS II RECEPTACLE ASSEMBLY 100 AMP; 3 WIRE, 4 POLE	59312768000	1	MD2SR1034F MD2SR1034U
12	30, 60, 100	GROUND LUG	59350996000	1	MD2SR3034F MD2SR6034F MD2SR1034F MD2SR1034U

WARNING

If any parts of the "MD2SR" unit appear to be missing, broken or show signs of damage:

DISCONTINUE USE IMMEDIATELY!

This condition could cause serious / fatal personal injury due to electrocution and / or equipment damage. Repair with the proper replacement part(s) before continuing service.

DURING THE INSPECTIONS, PERFORM AT LEAST THE FOLLOWING:

1. Electrical power must be turned "OFF" before performing maintenance.
2. Inspect all conductor terminations for secureness.
 - Retorque to values given previously in these instructions.
 - Discoloration due to excessive heat is an indication of possible problems and should be thoroughly investigated and repairs made as necessary.
3. Check grounding and bonding effectiveness / continuity.
 - **Retorque connections to original values.**
4. Check gaskets for damage. Replace as necessary.
5. Clean interior of all foreign materials.
6. Cover Bolts ① must be tightened to 25-30 lb.- ft. torque.
7. Make sure the Receptacle Assembly Nameplate located on the outside of the cover remains clean and legible.
 - **Do not paint Nameplate.**

It is recommended that an electrical preventive maintenance program, such as found in the National Fire Protection Bulletin NFPA no. 70B, be followed in addition to the above.

All statements, technical information and recommendations contained herein are based on information and tests we believe to be reliable. The accuracy or completeness thereof are not guaranteed. In accordance with Appleton Electric, LLC "Terms and Conditions of Sale", and since conditions of use are outside our control, the purchaser should determine the suitability of the product for his intended use and assumes all risk and liability whatsoever in connection herewith.

When finished with installation, file and retain these instructions for future reference during inspection and maintenance.